

SECTION A-A

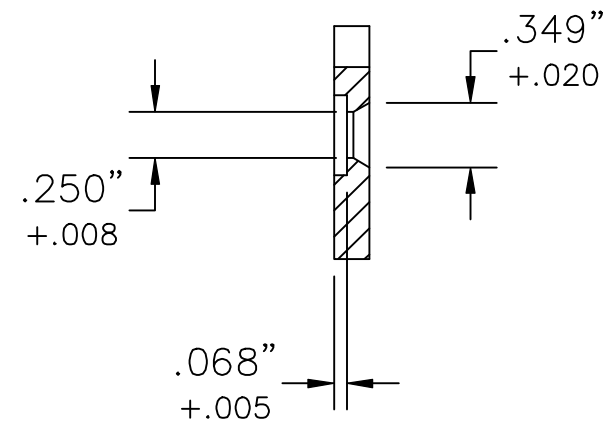

SECTION B-B

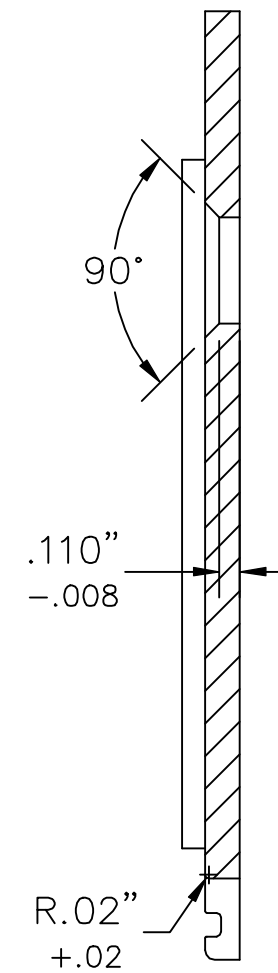

SECTION D-D

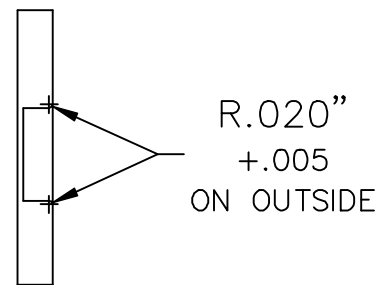

SECTION C-C

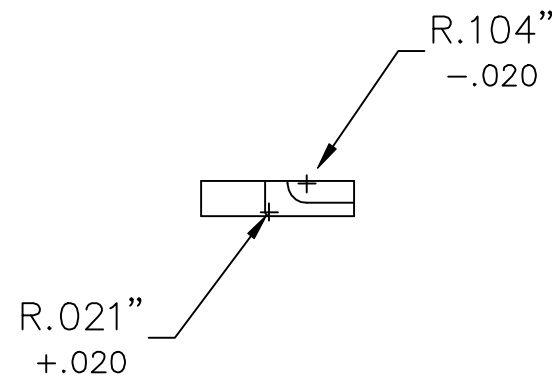

VIEW E

NOTES:

1. FINISH - **125** EXCEPT AS NOTED.
2. MATERIAL - STEEL, ASTM A331: 4340 OR 4130 OR 4140.
3. BREAK EDGES .003 +.012 UNLESS OTHERWISE SPECIFIED.
4. ALL RIVET HOLES ARE .187 DIA. +.001 (90° -1° CSK .052 +.020 DEEP) REAM AT ASSEMBLY UNLESS OTHERWISE SPECIFIED.
5. HEAT TREAT - HEAT LENGTH "F" TO 1480°~1500° F. OIL QUENCH, TEMPER AT APPROX. 800° F TO HARDNESS SPECIFIED.
6. MIL-W-13855 APPLIES.

M2HB .50 CAL BMG
RIGHT HAND SIDE PLATE

TOLERANCES		
DEC MM	2 PL	±.02 ±.51
DEC MM	3 PL	±.005 ±.127
ANGLES		±.5°

DRAWN BY KBH	DATE 02-27-2002
CHECKED BY	DRAWING NO
SCALE FULL	REV
M2HB .50 BMG RHSP_2	